

## The weight change of a body in connection with the electrical tension

H.-J. Hochecker

[physics.j@hochecker.eu](mailto:physics.j@hochecker.eu), [www.hochecker.eu](http://www.hochecker.eu)

Abstract: I stick metal foil on an a 1 square meter large and 10 kilograms heavy dielectric so that a condenser is build. By putting a tension of 10 kV on the condenser or by short-circuiting it I measure a real reduction of the weight of about 0.1 grams each time. This result confirms my theoretical conclusion which says that the weight of a body is related with the movements of its charges (protons and electrons).

Keywords: Gravitation, movement of electrical charges, relativity

PACS: 03.30.+p, 03.50.De, 12.10.-g

### 1. Introduction

In a more extensive theoretical work of mine [1] I come among others to the conclusion (under consideration of the theory of special relativity) that the weight of a body is related to the movements of the charges it consists of (the electrons and the protons). This effect depends on both the type and size of the charges (positive or negative) and on the direction of the movements (parallel or vertically to the gravitational field). To show that my assumption is correct, I must put the charges of a body into movement relatively to each other or relatively to the gravitational field and measure its weight at the same time. To this purpose I stick metal foil on a dielectric of  $1 \text{ m}^2$  area and 10 kg weight and therefore I produce a condenser. Then I hang this condenser on an unstable beam balance to be able to measure its weight while putting a tension (of 10 kV) on it or short-circuiting it. When the electrical field is turned on or off the atomic nucleuses of the atoms of the condenser move relatively to the electron shells. These charge movements produce a measurable weight change. All the control measurements have shown that it is a real weight change and not any another phenomenon. Much work is found to this topic; I mention some in the references [2][3][4][5].

### 2. The experiment

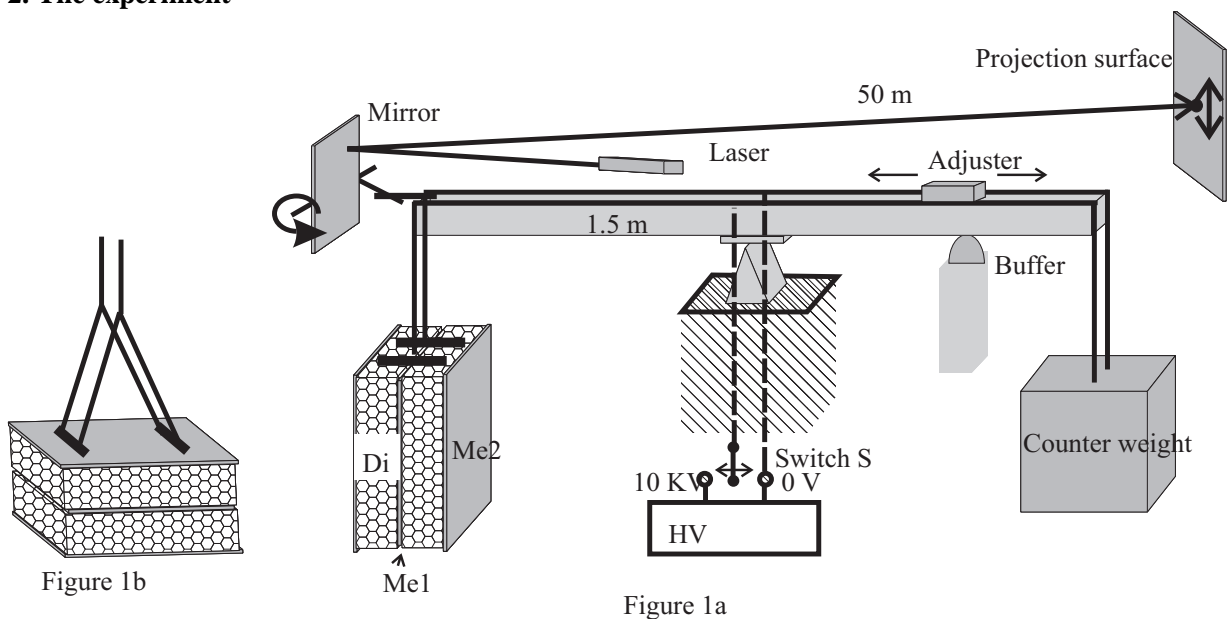

I take two plates of a synthetic material mixture (marked as Di in the Figure) as a dielectric with  $1 \text{ m}^2$  area and 5 kg weight each (and 8 mm thick). I stick a metal foil (marked as Me1 in the Figure) between these

two plates. I then wrap metal foil (Me2) round the two plates stuck together. I put the high tension (10 kV) to the inner metal foil while the outer metal foil is earthed. This way two condensers result which are symmetrical to the middle axis while the outsides don't have any electrostatic interactions with the surroundings. I hang this condenser on an unstable beam balance. At these kind of scales the centre of gravity is over the point of rotation so that smallest weight changes already disturb the balance considerably recognizably while the total weight of the condenser and the counterbalance (after all 20 kg) is lifted almost completely. To stabilize the system, I have installed a tender, elastic but short buffer made of synthetic material and for the adjustment I use a little runner. I represent the movements of the beam balance with the help of a laser in 50 meters of distance over a little lever to which a mirror is fastened. The advantage of this system consists that already very short and weak weight changes get considerably recognizable. I can put the high tension (voltage) to the condenser or short-circuit it with the switch S. At first, I hang the condenser vertically (Figure 1a), what means that the electric field is vertical to the gravitational field. When putting on the electric tension a clear deflection of the laser point is recognizable. The system then swings into the old position again. Short-circuiting the condenser then also leads to a considerably recognizable deflection of the laser point, and to be more precise in the same direction. In both cases (putting on the voltage and short-circuiting it) the deflection of the laser point corresponds to a *reduction* of the weight of the condenser. The reduction of the weight (that is the direction of the change) is considerably recognizable, unfortunately, the calibration of the system is quite inexact yet, however, so that I only can say that the weight reduction is at the maximum peak about 0.1 grams.

At next I have carried out a control measurement. To this I have hung up the condenser horizontally (Figure 1b). Here, no movements of the laser point are recognizable at all, when putting on the tension or when short-circuiting it. So the weight doesn't change.

### 3. Evaluation

When a tension is put to the condenser, then the atoms are polarized; this means that the atomic nucleuses and the electrons or electron shells move in opposite directions. Here, though, it doesn't depend on the direction but on the speed or the development. Due to the differences in the inertia and in the freedom of movement the atomic nucleuses and the electron shells move differently. This differences in the way the positive and negative charges move are in both cases the same, when the tension is put on and when it is short-circuited, what then explains why the weight changes in both cases in the same way.

The theoretical forecast is here that the weight decreases if the protons move. This is here definitely conceivable since the electron shells form the basic scaffolding which is firmly connected to the condenser and therefore doesn't move. The exact connections and processes are here still not quite clear, though and must be examined still more exactly. The theory only says that the weight depends on the relationship of the speeds of the positive and the negative charges.

According to the theoretical forecast it is primarily all about the movements (speeds) of the electrical charges vertically to the gravitational field. Movements parallel to the G-field shouldn't have influence (at least not in this range). This is excellently confirmed by the experiment when the condenser is hung horizontally.

Of course it also must be tried to exclude other possible reasons for the measurement result. Electrostatic effects can be excluded since the outside of the condenser remains on the same potential as the surroundings. In addition, the control measurement also has shown no effect. The same also applies to possible magnetic effects which would anyway be too weak to be measured since the condenser is hung up far in the vacant room. A mechanical impulse can already be excluded due to the symmetry in the construction, in addition, this would have been noticeable also at the control measurement. Thermal effects or changes in the impetus already can be excluded due to the shortness of the measurement and due to the clarity of the result.

#### Closing remark

The extensive theoretical considerations, the conscientious execution of the experiment, and the long search for other causes finally have led me to the conviction that it actually is a gravitational phenomenon. The far reaching consequences of this experiment and its theoretical considerations are definitely conscious to me so that I also understand the scepticism which is brought to it. It seems, this always must be so. But, as for the rest this experiment can be reproduced easily.

#### References

- [1] H.-J. Hochecker *Magnetism And Gravitation As A Result Of Geometric Changes In The Electric Field Caused By The Translation Of The Charges* [www.hochecker.eu](http://www.hochecker.eu)
- [2] C.P. Kouropoulos *Induced Gravity in the Short Range* arxiv:physics/0107027
- [3] V.E. Kuzmichev, V.V. Kuzmichev *Accelerating Quantum Universe* Acta Phys. Polon. B39:2003-2018, arxiv:0712.0465
- [4] J.E. Hirsch *Electromotive forces and the Meissner effect puzzle* Journal of Superconductivity and Novel Magnetism 23, 309-317 (2010)
- [5] S.N. Dolya, K.A. Beshetnikova *About the Electrodynamic Acceleration of Macroscopic Particles* Preprint JINR, R9-2009-110