

Light Faster than Light is a Common Phenomenon

António Saraiva -- 2009-06-07
ajps2@hotmail.com

See Unified Absolute Relativity Theory at:

<http://www.wbabin.net/saraiva/saraiva105.pdf>

<http://www.wbabin.net/saraiva/saraiva223.pdf>

Light faster than light is a common phenomenon in optical media.
X rays have a faster than light speed in glass and visible light has a faster than light speed in gold. Orthodox physics says nothing about this.

This phenomena is a proof of our theory and a proof a our formula of light speed:

$$w = \sqrt{c^2 - kf^2}$$

Silicon refractive index

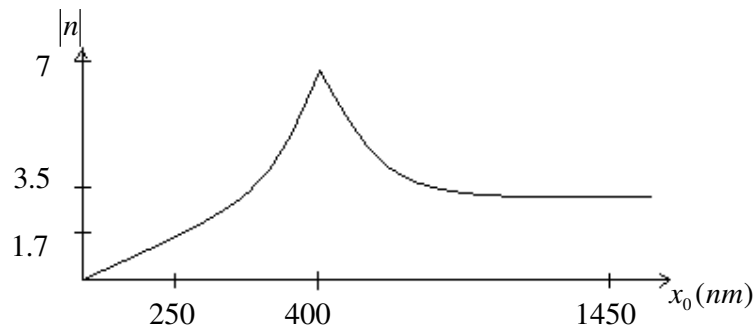

$$n_0 = 3.5 ; \quad n_{MX} = 7$$

The formula:

$$n = \frac{1.5cn_0}{\sqrt{|c^2 - kf^2|} + 0.5c}$$

$$n = \frac{1.5cn_0}{\sqrt{|c^2 - kf_0^2 \frac{2c}{\Delta v}|} + 0.5c}$$

$$\Delta v = \left| \frac{n+1}{n-1} \right| \frac{kf_0^2}{2c} ; \quad \Delta v = \frac{10cf_{0MX}^2}{f_M^2}$$

For $n < 0.9$ we have longitudinal waves with speed greater than light speed.~
 This happens for a Ultraviolet frequency $f_0 > 2.5 \times 10^{15} \text{ Hz}$ but the transmission is almost zero.

Gallium phosphide

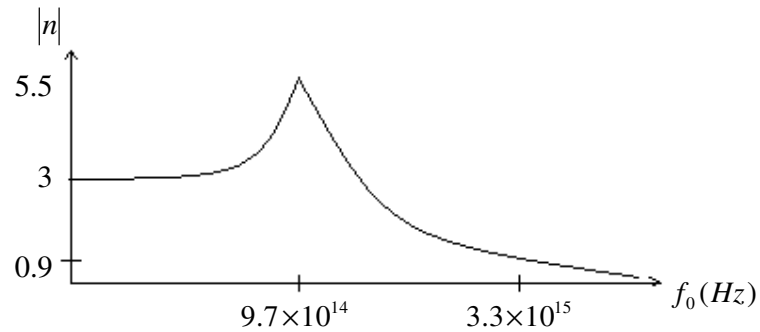

$$n_0 = 3 ; \quad n_{MX} = 5.5$$

$$\Delta v = \frac{10cf_{0MX}^2}{f_M^2} = 6 \times 10^{-12}$$

$$w > c \quad \Leftrightarrow \quad 1.5f_M = f_0 \sqrt{\frac{2c}{\Delta v}}$$

$$f_0 > 3.3 \times 10^{15} \text{ Hz}$$

For this frequency light speed is greater than light speed. The transmission is almost zero.

Theoretical graphic of the water

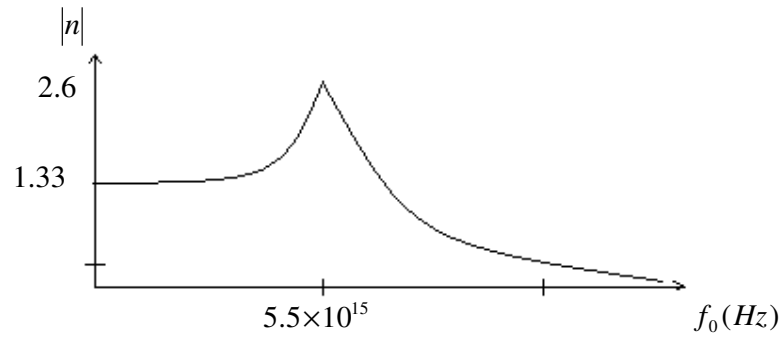

For speeds greater than light speed:

$$n < 0.9 \quad \Leftrightarrow \quad f = f_M \frac{\sqrt{n^2 + 1}}{n} = 1.5 f_M$$

$$\Delta v = \frac{10 c f_{0MX}^2}{f_M^2} = 1.93 \times 10^{-10}$$

$$f = f_0 \sqrt{\frac{2c}{\Delta v}} \quad ; \quad f_0 = 1.84 \times 10^{16} \text{ Hz}$$

As is already known x rays of this frequency have a speed greater than light speed. Transmission is almost 100%.

Theoretical normal glass

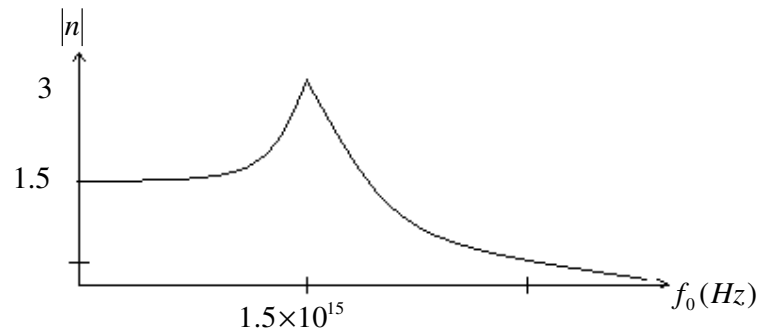

$$\Delta v = 1.4 \times 10^{-11} \quad ; \quad f_0 = 5 \times 10^{15} \text{ Hz}$$

For this frequency we have longitudinal waves inside the glass with a speed greater than light speed.

Gold refractive index

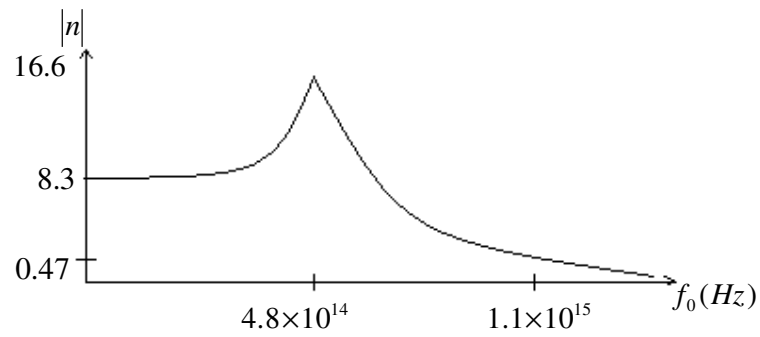

Symmetric detector-clock

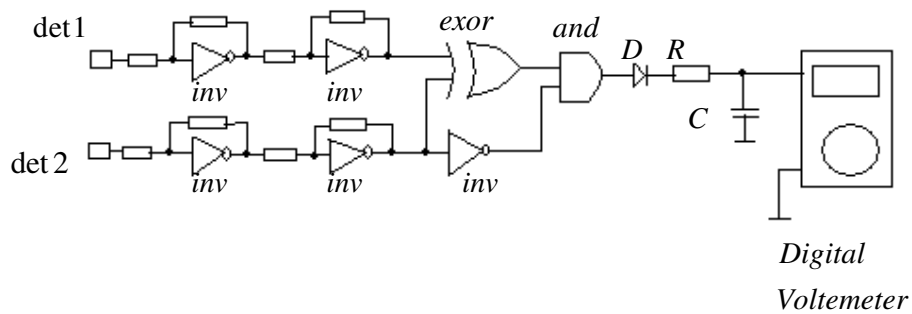

Det1, det2 – Ultraviolet photodiodes

Inv – logic inverters. With resistors R working as amplifiers (x10000)

□ -- Resistors (R)

Exor – Logic gate exclusive or

And – Logic gate and

D – Signal diode

C – Capacitor

$$d = 0.2m$$

$$\Delta t = \frac{d}{c} \left(1 - \frac{1}{1.11} \right) = 65.62 ps$$

$$\Delta t = RC \log \left(\frac{V_0}{V_0 - V_0/2} \right) = RC \log 2$$

$$RC = 94.67 ps \quad \text{and} \quad C = 1 \times 10^{-12} F$$

$$R = 94.7 \Omega \quad \text{--} \quad R = 100 \Omega$$